

# METERED WATER STORAGE

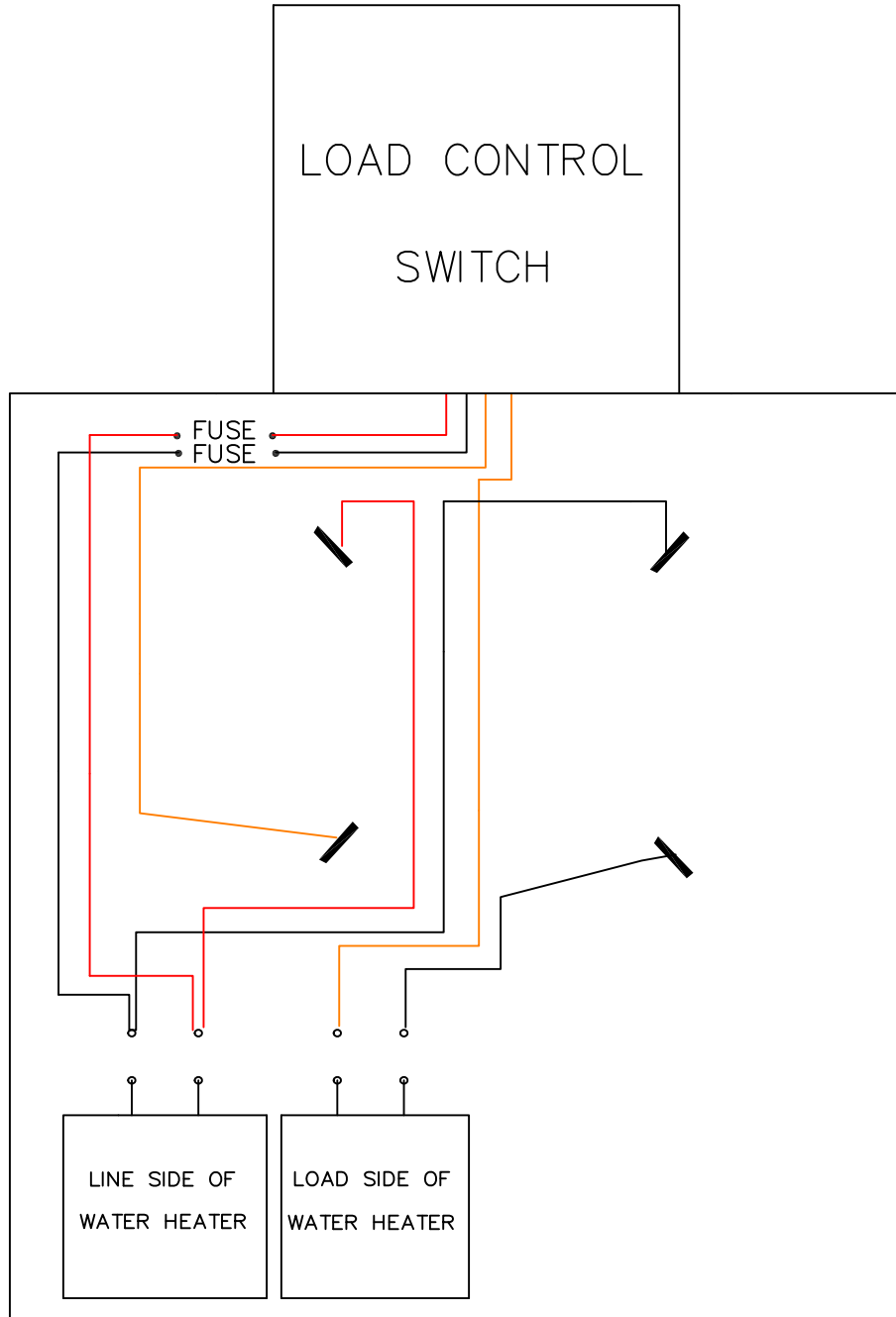

**NOTES:**

- 1 WRIGHT-HENNEPIN C.E.A. IS NOT RESPONSIBLE OR LIABLE FOR ANY PERSONAL INJURY OR PROPERTY DAMAGE IN THE WIRING OF OR THE OPERATION OF THIS ENERGY SAVINGS PROGRAM.
- 2 ALL WIRING MUST MEET N.E.C. (NATIONAL ELECTRIC CODE) AND BE INSPECTED BY A STATE ELECTRICAL INSPECTOR BEFORE WRIGHT-HENNEPIN WILL INSTALL METER.
- 3 LOAD CONTROL SWITCH AND METER SOCKET MUST BE MOUNTED OUTSIDE 4' TO 5' OFF THE GROUND.
- 4 ANY TIME POWER IS OFF AND RESTORED TO THE LOAD CONTROL SWITCH THERE WILL BE A 15 MINUTE DELAY BEFORE UNIT WILL BE ALLOWED TO OPERATE.



WRIGHT HENNEPIN COOPERATIVE ELECTRIC ASSOCIATION  
Energy and Services Department  
(800) 943-2667

METERED WATER STORAGE

LM18

12/21/18

BY: ERA