

REMOTE CT FOR ELECTRIC VEHICLE – 100% ELECTRIC

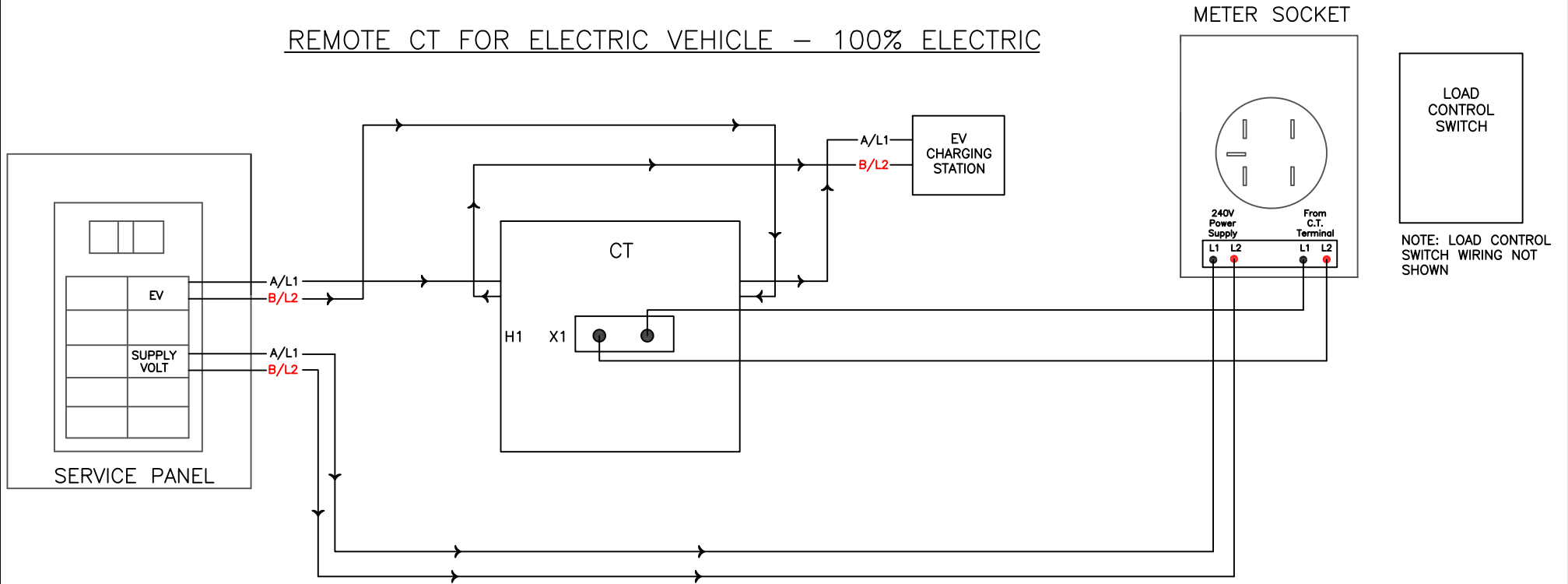

1. Wright Hennepin Cooperative Electric Association will not be responsible or liable for any personal injury or property damage in the wiring of or the operation of this or any Energy Savings Program. Wright Hennepin recommends the use of a licensed electrical contractor.
2. All wiring must meet N.E.C. (National Electrical Code) and be inspected by a state electrical inspector before Wright Hennepin will check out installation, credit KWH usage or issue any applicable rebates.
3. Any time power is off & restored to the radio receiver, there will be a 15 minute time delay before unit will be allowed to operate.
4. Load control switch/meter socket must be mounted 4' to 6' above the ground outside of all structures with ample access around unit.
5. Mount load control switch above or next to meter socket.



WRIGHT HENNEPIN COOPERATIVE ELECTRIC ASSOCIATION
Energy and Services Department
(800) 943-2667