

# DIRECT METERED

## DUAL 200 AMP SOCKET/DUAL FUEL OTHER

1. Wright Hennepin Cooperative Electric Association (WH) will not be responsible or liable for any personal injury or property damage in the wiring of or the operation of this or any Energy Savings Program. WH recommends the use of a licensed electrical contractor.
2. All wiring must meet N.E.C. (National Electrical Code) and be inspected by a state electrical inspector before Wright Hennepin will check out installation, credit KWH usage or issue any applicable rebates.
3. Radio receiver/meter socket must be mounted 4' to 6' above the ground outside of all structures with ample access around unit.
4. Off peak meter must be on right and main on left of socket.
5. A red light indicates that a load is being controlled.
6. Red and black wire from radio receiver should get 240V power from O.P. meter.
7. The #10 AWG pair of wires in radio receiver break 1 leg of water heater power.
8. The #16 AWG pair of wires in radio receiver break the (W) leg for electric heat or (Y) leg for central A/C.
9. An auxiliary relay or second LCS will be needed to control 3 or more loads.
10. Water Heater Circuit must be installed in General Service Panel.

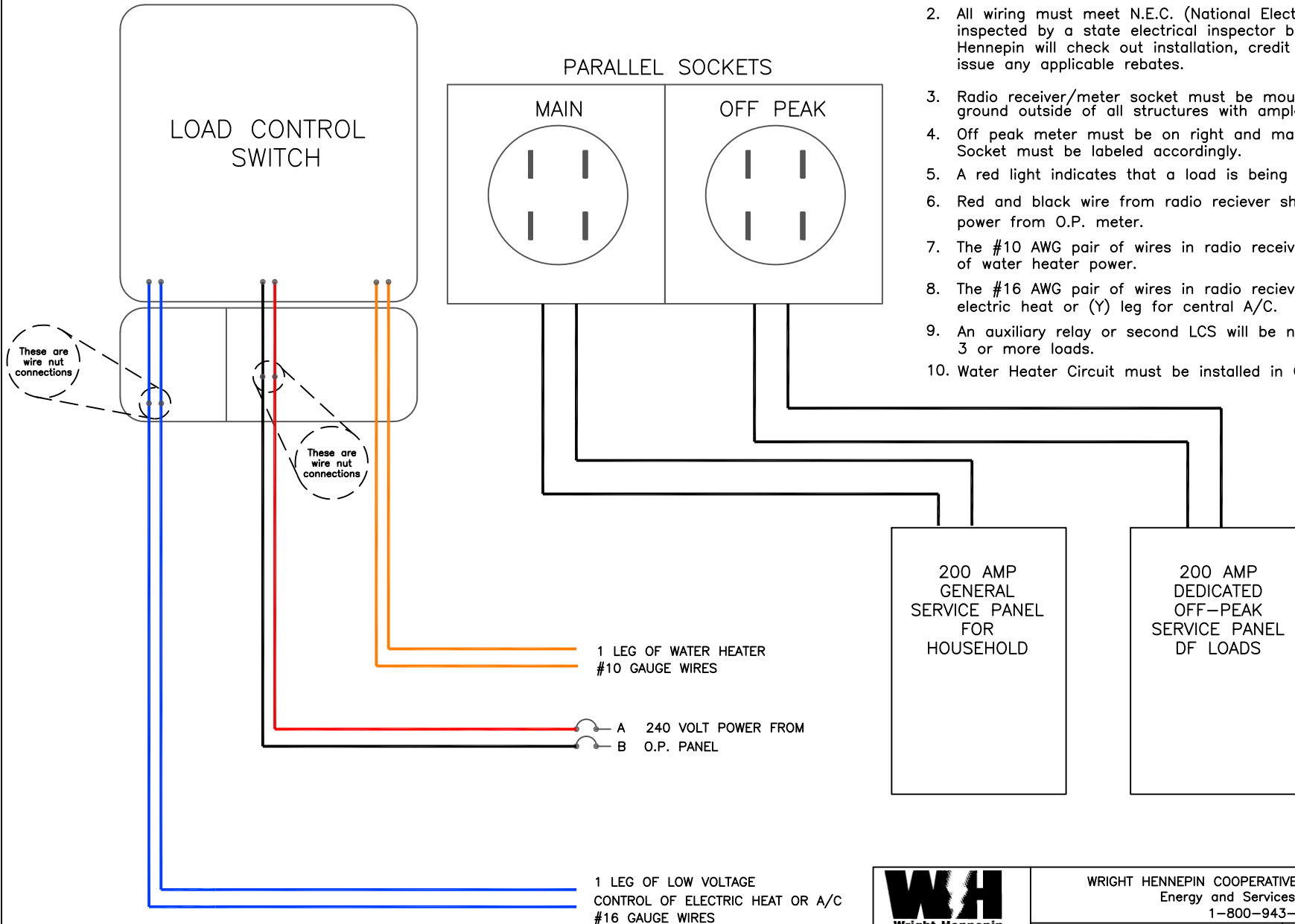

WRIGHT HENNEPIN COOPERATIVE ELECTRIC ASSOCIATION  
Energy and Services Department  
1-800-943-2667

DUAL 200 AMP SOCKET

LM4D

12/21/18

BY: ERA