

QUICK CASH STORED WATER
 NON METERED FOR LANDIS & GYR
 Model # FASY-0530-0008

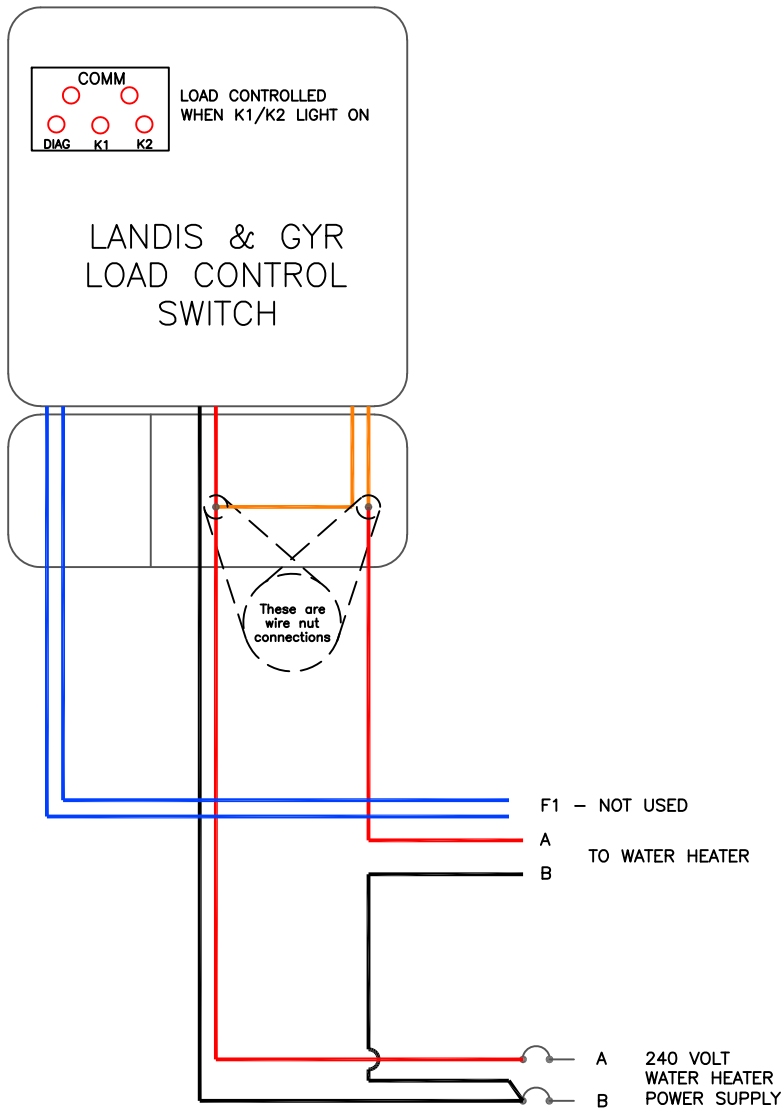

1. Wright Hennepin Cooperative Electric Association will not be responsible or liable for any personal injury or property damage in the wiring of or the operation of this or any Energy Savings Program system. Wright-Hennepin recommends the use of a licensed electrical contractor.
2. All wiring must meet N.E.C. (National Electrical Code) and be inspected by a state electrical inspector before Wright Hennepin will check out installation, credit KWH usage or issue any applicable rebates.
3. Load Control Switch must be mounted outside the home and 4' to 6' above the ground.
4. A red light indicates that a load is being controlled.
5. Water heater circuit powers load control switch.
6. The (A) Phase of water heater power is wired in series with the orange wires of the load control switch.

Red } 240 V.A.C. POWER
 Black }